

Economic Implications of 21-Gene Breast Cancer Risk Assay from the Perspective of an Israeli-Managed Health-Care Organization

Shmuel H. Klang, PhD,¹ Ariel Hammerman, PhD,¹ Nicky Liebermann, MD,¹ Noa Efrat, MD,² Julie Doberne, BS,³ John Hornberger, MD, MS^{3,4}

¹Clalit Health Services, Tel-Aviv, Israel; ²Kaplan Medical Center, Rehovot, Israel; ³Cedar Associates LLC, Menlo Park, CA, USA; ⁴Stanford University School of Medicine, Stanford, CA, USA

ABSTRACT

Objective: *Oncotype DX*, a 21-gene assay, was clinically validated as a predictor of 10-year recurrence-free survival and treatment response in patients with early-stage estrogen-receptor-positive, lymph-node negative breast cancer (ER+ LN- ESBC). This study determined “real-life” alteration in treatment decision and economic implications of *Oncotype DX* use in women with ER+ LN- ESBC.

Methods: Clalit Health Services (CHS, Tel Aviv, Israel), determined the proportion of women in low, intermediate and high-risk groups in the first 368 *Oncotype DX* assays performed, the change of adjuvant therapy recommendation following the recurrence (RS) results from *Oncotype DX* use, and associated chemotherapy costs. The risk of recurrence-free survival was derived from prespecified statistical protocols of NCI-sponsored trials conducted by NSABP (B-14 and B-20). Utilities were literature based. A 3% discount rate was employed.

Results: *Oncotype DX* altered recommendations of 40% of patients, 84% of whom were changed from hormone + chemotherapy to hormonal therapy alone. Among high-risk women, 8% switched actual treatment from hormonal therapy to hormone + chemotherapy. By reducing the chemotherapy disutility, quality-adjusted life-years (QALY) increased 0.170 years. Use of *Oncotype DX* costs \$10,770 per QALY gained. Sensitivity analyses revealed that risk reduction in the low-risk population, the cost of adverse events, and the relative risk reduction of recurrence were the most influential variables.

Conclusion: *Oncotype DX* resulted in net QALY gain and increased overall costs, with an incremental cost-effectiveness ratio of \$10,770. For CHS, *Oncotype DX* represents an effective and affordable approach to favorably affect the lives of women with ESBC.

Keywords: Breast cancer, costs, early stage breast cancer, economics, gene assay, molecular classifier, *Oncotype DX*.

Introduction

Approximately 90 women per 100,000 are diagnosed yearly with breast cancer in Israel [1]. Breast cancer remains among the most common cancers in women, and the most common cause of death among women between the ages of 40 and 79 [2]. Several large randomized clinical trials demonstrated the benefit of hormonal therapy in patients with estrogen receptor-positive (ER+) early-stage breast cancer (ESBC). An important decision for a patient with ER+, lymph node-negative (LN-) ESBC is whether to also undergo adjuvant chemotherapy after primary surgery to prevent or delay distant recurrence. Chemotherapy-related adverse events occur in almost all patients, and more than 1 in 10 women experience a serious or life-threatening event [3]. Between 1 in 100 and 1 in 500 women die from side effects related to the administration of chemotherapy. Other adverse effects include ovarian failure, cardiotoxicity, nausea, and hair loss. Consensus guidelines recommend considering adjuvant chemotherapy if tumor size is greater than 0.6 cm [4]. Experts do not recommend routine use of adjuvant chemotherapy for patients over 70 years old and advocate for individualized treatment with consideration of comorbid conditions [4].

Enhanced public health efforts to detect breast cancer, such as mammographic screening, have increased detection at earlier stages of disease [5]. The success of these efforts has resulted in physicians and patients more regularly facing the question: Do

the benefits of adjuvant chemotherapy outweigh the medical risks and known adverse effects on quality of life? The difficulty in answering this question is supported by recent evidence showing wide variation in the propensity to prescribe adjuvant chemotherapy, a variation that cannot be explained by characteristic risk factors such as age, tumor size, and histology [3,6]. Thus, an active area of oncology research is identifying additional reliable predictors of recurrence in ESBC that would assign risk more accurately and help guide the decision to prescribe adjuvant chemotherapy.

Oncotype DX (Genomic Health, Inc., Redwood City, CA, USA) is a genomic test that predicts the average rate of distant recurrence of breast cancer and response to adjuvant chemotherapy treatment. The *Oncotype DX* assay uses a reverse-transcriptase, polymerase chain reaction process to quantify the presence of specific mRNA for 16 cancer genes, and 5 reference genes in paraffin samples obtained from a breast cancer biopsy. The results are combined into a single score, quantified on a scale of 0 (lower risk) to 100 (higher risk). The test has the most value as a continuous variable; however, patients can be further subdivided into three risk groups: patients receiving a score of 0–17 are considered to have a low risk of recurrence, while patients with a score of 18–30 are considered to have an intermediate risk of recurrence. Patients with a score of 31 or higher are considered to have a high risk of recurrence.

Oncotype DX's clinical validity was tested in prespecified subgroup analyses of randomized clinical trials (National Surgical Adjuvant Breast and Bowel Project studies [NSABP] B-14 and B-20), and was shown to independently predict distant recurrence of breast cancer at 10 years and response to

Address correspondence to: John Hornberger, 275 Middlefield Road Ste 200, Menlo Park, CA 94025, USA. E-mail: jhornberger@cedarecon.com 10.1111/j.1524-4733.2010.00724.x

adjuvant chemotherapy using cyclophosphamide-methotrexate-5-fluorouracil regimens [7,8].

Experience from several university- and community-based groups has shown that the *Oncotype* DX assay has influenced decisions about whether to undergo chemotherapy [9–12]. In studies conducted in the United States and Israel, 20% to 25% of women classified as low risk of distant recurrence elected to change therapy from adjuvant chemotherapy plus hormone therapy to hormone therapy only [10,13–15]. For the 25 out of 100 women predicted to have a high risk of distant recurrence, the *Oncotype* DX assay identified at least 1 woman per 100 who initially decided to use only hormone therapy and subsequently elected to also undergo a course of adjuvant chemotherapy based on the high *Oncotype* DX score [8].

In February 2006, Clalit Health Services (CHS), Israel’s largest health-care organization with 3.6 million members, was the first public health insurer to reimburse the assay outside the United States. The coverage decision was based on the assay’s clinical validation, recommendations by Israeli oncology opinion leaders, and findings of potential cost-effectiveness of the assay under a wide range of assumptions [15,16].

The primary aim of this study was to assess the validity of the cost-effectiveness of *Oncotype* DX compared with traditional prognostic pathways in the diagnosis and treatment of ER+, LN-, ESBC from an Israeli health-care provider perspective. A secondary aim was to assess the factors that influence the cost-effectiveness of *Oncotype* DX use.

Methods

Analytical Framework

The analytical framework was a Markov model, which simulated the costs associated with and without use of the *Oncotype* DX assay (Fig. 1). The cost implications of both patient groups—patients using *Oncotype* DX and those without—were compiled. The analysis was performed from a payer’s perspective. CHS provided the data on the risk of recurrence in the

Israeli population. Sensitivity analyses were performed to assess the impact of different variables on the cost-effectiveness of the assay.

Data Sources

Data was collected from the first 368 *Oncotype* DX assays reimbursed by CHS. Researchers collected forms completed by the treating oncologist containing information on relevant biological data, the physician’s treatment recommendation before knowledge of *Oncotype* DX assay results, and the treatment to be offered to the patient according to each of the three possible risk levels: low, intermediate, and high. Data on the actual treatment provided to the patient was collected from CHS’s electronic billing database.

Risk of Recurrence and Death

The annual risk of death by age for women was based on data from the National Center for Health Statistics [17]. Along with data from NSABP studies B-14 and B-20 published in 2004 and 2006 by Paik et al., these data were used to estimate the risk of distant recurrence [7,8].

Costs

The cost of the assay was based on the manufacturer’s suggested retail price of \$3460. The CHS provided costs for chemotherapy and supportive costs equal to \$3540 and \$243, respectively (Table 1). The incidence of early adverse events was based on published reports of key trials of anthracycline therapy [6]. Late adverse events include ovarian failure and cognitive dysfunction. Management of chemotherapy-related adverse events cost \$2249, and the associated cost per subsequent breast cancer recurrence was approximately \$10,000. Cycle length for time until recurrence or death was 1 year, and a time discount rate of 3% was applied for both costs and benefits as per the recommendations made by the US Panel on Cost-Effectiveness in Health and Medicine [18].

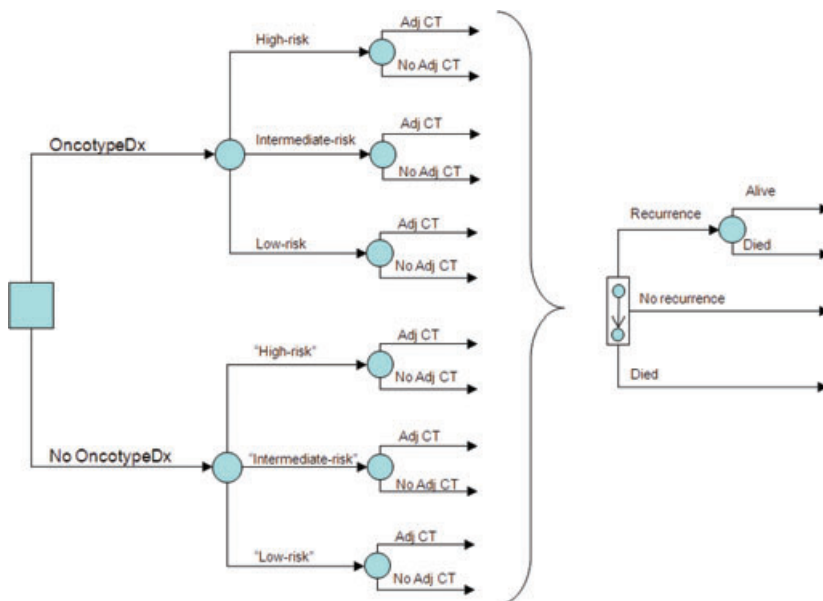

Figure 1 Markov diagram. Level of risk according to *Oncotype* DX. Values without quotations are known to physician/patient, whereas values with quotations are unknown to physician/patient. Adj CT, adjuvant chemotherapy.

Table 1 Relative reduction of recurrence by Oncotype DX risk group, cost and utilities

Parameter	Mean input values	Low	High	Distribution	Data source	Evidence grade
Relative reduction of recurrence with chemotherapy, by Oncotype DX risk group						
Low-risk	131%	46%	373%	Lognormal	Paik [8]	I-A
Intermediate-risk	61%	24%	155%	Lognormal	Paik [8]	I-A
High-risk	26%	13%	52%	Lognormal	Paik [8]	I-A
Costs, average per patient						
Associated with chemotherapy						
Adjuvant chemotherapy regimen	\$3,540	\$3,003	\$4,173	Lognormal	CHS	P-A
Supportive care	\$243	\$47	\$1,259	Lognormal	CHS	P-A
Adverse events	\$2,249	\$434	\$11,650	Lognormal	CHS	P-A
Per recurrence	\$10,000	\$1,930	\$51,803	Lognormal	CHS	P-C
Oncotype DX	\$3,460	—	—	Not applicable	CHS	P-A
QALY loss with chemotherapy and cancers						
Chemotherapy	0.5	0.3	0.7	Normal	[19,21–23]	P-C
Recurrence	9.1	6.5	12.6	Normal	[19,21–23]	P-C
Other assumptions						
Discount rate (for NPV computations of recurrence costs)	3%	—	—	Not applicable	Lipscomb [18]	P-A
Time horizon, years	30 or lifetime	—	—	Not applicable	Expert opinion	P-A

See Appendix for summary of evidence grade.
CHS, Clalit Health Services; NPV, net present value; QALY, quality-adjusted life-years.

Health Utilities

Health utility scores, which are quantitative representations (0 = death, 1 = perfect health) of the desirability of a particular health outcome, were used to calculate quality-adjusted life-years (QALY). Utility scores for the following health states were obtained from the literature: breast cancer during chemotherapy, breast cancer recurrence, and second primary cancer caused by chemotherapy. Utility scores were derived from the sum of the disutility associated with chemotherapy and the disutility associated with recurrence (Table 1) [19–23].

Sensitivity Analyses

In the one-way sensitivity analysis, each of the parameters that drive the model were varied one at a time. These model parameters can be viewed in Figure 2. The impact of the parameter on major performance metric, cost per QALY, was noted. Parameters were then sorted by decreasing level of importance and plotted with order of importance on the vertical axis and change in cost per QALY on the horizontal axis.

Probabilistic sensitivity analysis (PSA) employs a Monte Carlo simulation to assess the variability of the cost per QALY as key parameters independently change according to pre-assigned probability distributions. These distributions capture the range of variability likely for each parameter. In the PSA, each key parameter is modeled according to distributions for the type of parameter typically reported in *Value in Health* publications. Beta distributions were used for proportions. Normal distributions were used for logarithm of costs and relative risk reductions. Normal distributions were used for QALY losses associated with chemotherapy and recurrence of breast cancer. Ranges were based on literature values for that variable if reported (i.e., recurrence rates); otherwise, they were based on norms of ranges published for PSAs in *Value in Health* over the past 2 years (Fig. 2).

Quality of Evidence

Evidence was sought from the best available sources, including the clinical trial itself, based on systematic searches of the litera-

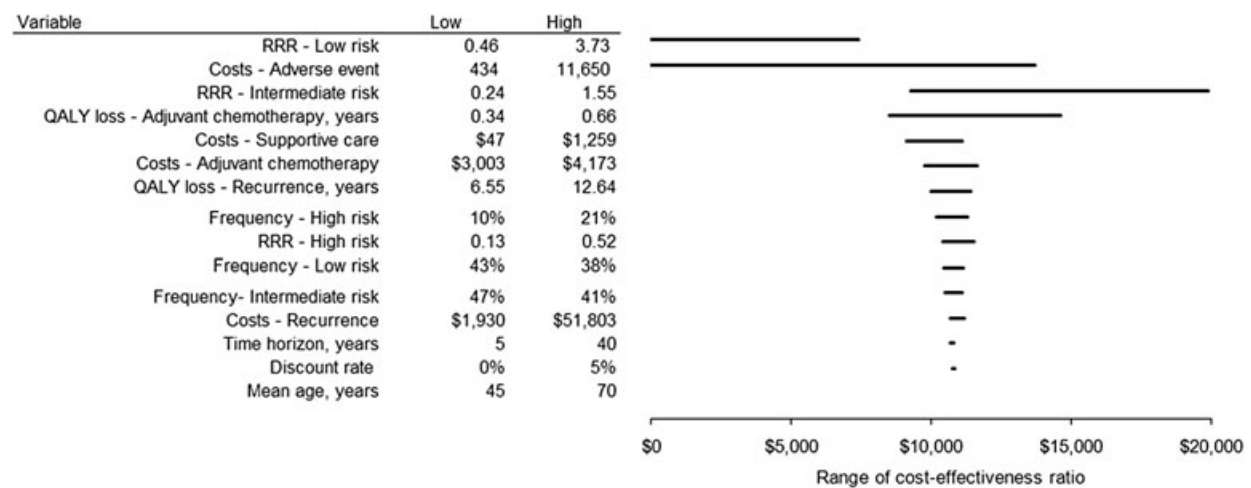

Figure 2 Sensitivity analysis tornado diagram. *At lowest range of input variable, Oncotype DX benefits patients and saves costs. QALY, quality-adjusted life-years.

ture using PubMed (United States National Library of Medicine, Bethesda, MD) and ISI Web of Knowledge Web of Science (Thomson Reuters, New York, NY, USA). In instances where no published data was available, evidence was based on consultations with experts. The quality of the evidence is graded based on study design, results, and limitations using two grading systems [24,25]. The first system assesses evidence pertaining to inference about treatment effects. The grading system assumes that findings from a well-controlled randomized clinical trial represent level A evidence, whereas findings from an observational study represent level B evidence. Level C evidence derives from other sources, such as expert opinion or small case series. The grading level is altered by one or two levels based additional criteria, such as strength of association, consistency of findings, level of potential reporting bias, concerns about study limitations, and generalizability of the findings.

For the second grading system, level A evidence represents data obtained from the stakeholder. For example, if the analysis is done from the perspective of the Centers for Medicare and Medicaid services (CMS), level A evidence would be based on CMS claims analyses. Another example is obtaining evidence from a utility assessment project, where the participants are a random sample from the stakeholder's stated constituency. Level B evidence involves obtaining estimates that pertain to the stakeholder perspective, but was not directly analyzed for this project (e.g., from a review of the literature). Level C evidence represents data obtained from other database sources, such as utility or cost registries. Level D evidence represents data from other sources, such as Delphi panel of experts. The grading level can be altered to reflect strengths and limitations of the study. It is worth noting that utility or cost data from a randomized controlled trial may be graded from A to C, depending on the particular relevance of the information to the stakeholder. For example, cost data analyzed in a trial in which most of the participants were from a country or health-care system substantially different from that of the stakeholder has lower relevance, and so may be assigned to level C evidence.

Results

Records were assessed for the first 368 *Oncotype* DX assays ordered at CHS; however, the first 55 patients did not have a reported treatment recommendation prior to ordering the test. This is typical with introduction of a new technology because 1) the clinicians are learning about the technology and how to interpret the results, and 2) CHS physicians decided subsequent to first using the test to obtain prospective information about their decision-making processes. The median patient age was 57 years (range 29–81 years) (Table 2). The median tumor size was 1.5 cm (range 0.3–4.5 cm). Using criteria from the American Joint Commission on Cancer [26], 9% of patients had tumor

Table 2 Summary of the baseline patient and tumor characteristics

Characteristic	Value (range)
Demographics	
Female, %	99
Age, mean (range), years	57 (29–81)
Tumor staging	
Median tumor size, cm	1.5 (0.3–4.5)
Tumor grade,* %	
1	9
2	66
3	25
Oncotype DX risk group (score)	
Low-risk (0–17), %	40
Intermediate-risk (18–30), %	45
High-risk (> 30), %	16

*American Joint Commission on Cancer criterion.

grade 1, 66% had tumor grade 2, and 25% had tumor grade 3. The proportion of patients classified by the *Oncotype* DX assay as low-risk (score 0–17), intermediate-risk (score 18–30), and high-risk (score > 30) was 40, 45, and 16%, respectively.

Prior to receiving the assay results, chemotherapy was offered to 174 patients (56%) (Table 3). After receiving the assay results, 125 patients' (40%) actual treatment differed from the initial recommendation. One hundred five patients (34%) received only hormone therapy instead of the initial recommendation of adjuvant chemotherapy plus hormone therapy.

The most substantial change from the original physician recommendation occurred among patients classified as low-risk by *Oncotype* DX. Prior to *Oncotype* DX classification, 63 low-risk patients (50%) were recommended to undergo chemotherapy; none of these patients subsequently received chemotherapy (Table 3). Among patients with intermediate-risk *Oncotype* DX score, the proportion of patients undergoing chemotherapy declined to 33% from an initial 51% of patients recommended to receive chemotherapy. Among high-risk patients, the proportion of patients undergoing chemotherapy increased from 85% to 93% of patients recommended to undergo chemotherapy prior to receiving information on the *Oncotype* DX score.

Oncotype DX costs \$3460 per patient (Table 4). A cost savings resulted from the reduced use of adjuvant chemotherapy. This is because a lower percentage of patients actually received adjuvant chemotherapy than were initially recommended by a physician prior to receiving information regarding their risk classification from *Oncotype* DX. Savings associated with chemotherapy, supportive care, and fewer adverse events were \$968, \$66, and \$615, respectively. The proper administration of chemotherapy to high-risk patients, who switch from hormone-only treatment after *Oncotype* DX, resulted in \$66 dollars of savings from preventing recurrence. The net average cost associated with *Oncotype* DX testing was \$1828 per patient. For CHS, *Oncotype*

Table 3 Adjuvant chemotherapy recommended before compared with actual use after receiving information on *Oncotype* DX risk status

Oncotype DX risk group	Proportion of patients by risk group		Total
	Recommended chemotherapy prior to <i>Oncotype</i> DX*	Recommended chemotherapy after <i>Oncotype</i> DX†	
Low risk (score 0–17)	63 (50%)	0 (0%)	127
Intermediate-risk (score 18–30)	72 (51%)	46 (33%)	140
High-risk (score > 30)	39 (85%)	43 (93%)	46
Total	174 (56%)	89 (28%)	313‡

*Percent in parentheses represents the proportion of patients in that risk group who were recommended to undergo chemotherapy prior to receiving information on *Oncotype* DX score.

†Percent in parentheses represents the proportion of patients in that risk group who actually underwent chemotherapy after receiving information on *Oncotype* DX score.

‡A total of 313 patients recorded treatment recommendations both prior to and after receiving the *Oncotype* DX assay.

Table 4 Results

End point	Mean value
Costs, per patient tested	
Oncotype DX	\$3460
Reduced use of adjuvant chemotherapy (actual*)	
Chemotherapy drugs	(\$968)
Supportive care	(\$66)
Adverse events	(\$615)
Recurrence costs (projected)	\$17
Total	\$1828
Total costs per plan*	
First year after diagnosis and testing	\$1,560,520
After first year from reduced recurrence risk	(\$52,422)
QALYs gained	
Chemotherapy related	0.136
Recurrence	0.034
Total	0.170
Cost per QALY gained	\$10,770

*Reduction in chemotherapy costs were actually realized by Clalit Health Services. The reduction in cost from reduced risk of recurrence—for the 8% of high-risk patients who initially were recommended hormonal therapy only and then switched to also receive adjuvant chemotherapy—are projections. QALY, quality-adjusted life-years.

DX increased total costs by \$1,560,520 in the first year after initial diagnosis of breast cancer and genomic testing (\$0.0338 per member per month). Oncotype DX was projected to cost \$14,717 through risk reduction for the 8% of high-risk patients who appropriately receive adjuvant chemotherapy as a result of testing.

The average QALY gained per patient associated with reduced use of adjuvant chemotherapy was 0.136 years (Table 4). For the 8% of high-risk patients who initially were recommended hormone therapy only and then switched to also receive adjuvant chemotherapy, the average QALY associated with reduction in recurrence was 0.034 years. The net QALY gained was 0.170 years per patient. The resulting cost per QALY gained was \$10,770.

Figure 2 shows the results of the one-way sensitivity analyses. The cost per QALY gained was less than \$20,000 for all variables. The three most influential variables influencing the cost-effectiveness of Oncotype DX were relative risk reduction in the low risk population, the cost of adverse events, and the relative risk reduction of recurrence in the intermediate risk population. There is a 5% probability that the cost per QALY gained exceeds \$35,000 (Fig. 3).

Discussion

Adjuvant chemotherapy is a widely prescribed treatment in ER+, LN- ESBC. Because the likelihood of distant recurrence within 10 years among all tamoxifen-treated patients is less than 20%, professional commentators have claimed that at least 80% of patients would be overtreated with adjuvant chemotherapy if it were offered to everyone [8]. Prior to testing with Oncotype DX, more than 50% of patients at CHS were recommended to undergo adjuvant chemotherapy.

Oncotype DX was developed, in part, to more reliably predict who would benefit from adjuvant chemotherapy, which then should reduce the unnecessary use of adjuvant chemotherapy among low-risk patients and increase the use of adjuvant chemotherapy among high-risk patients. Oncotype DX has undergone rigorous clinical validation using prespecified statistical protocols applied to randomized controlled trials [7,8], and has been endorsed by guidelines of the American Society of Clinical Oncology and the National Comprehensive Cancer Network as a means to reduce risk and costs for cancer patients [4,27].

We project that patients' lives will be extended and improved by the avoidance of adjuvant chemotherapy among low-risk patients and the use of adjuvant chemotherapy among high-risk patients. With the CHS, use of Oncotype DX increases overall costs by approximately \$1828 per patient tested. Nevertheless, as a consequence of improved quality-adjusted survival, the assay costs no more on average than \$11,000 per QALY gained. Extensive sensitivity analyses showed that incremental cost-effectiveness is likely to remain less than \$12,000 under the most reasonable assumptions, a value that is substantially below thresholds of acceptable cost-effectiveness among countries in the Organisation for Economic Co-operation and Development, such as Israel [28].

This study has several limitations. First, the clinical data on which the analyses were based came from a nonrandomly selected sample of patients at CHS. It is possible that these patients could potentially yield a higher proportion of patients' decisions altered by Oncotype DX than the population at large. For example, physicians may have selected patients in whom the physician has substantial uncertainty about the optimal treat-

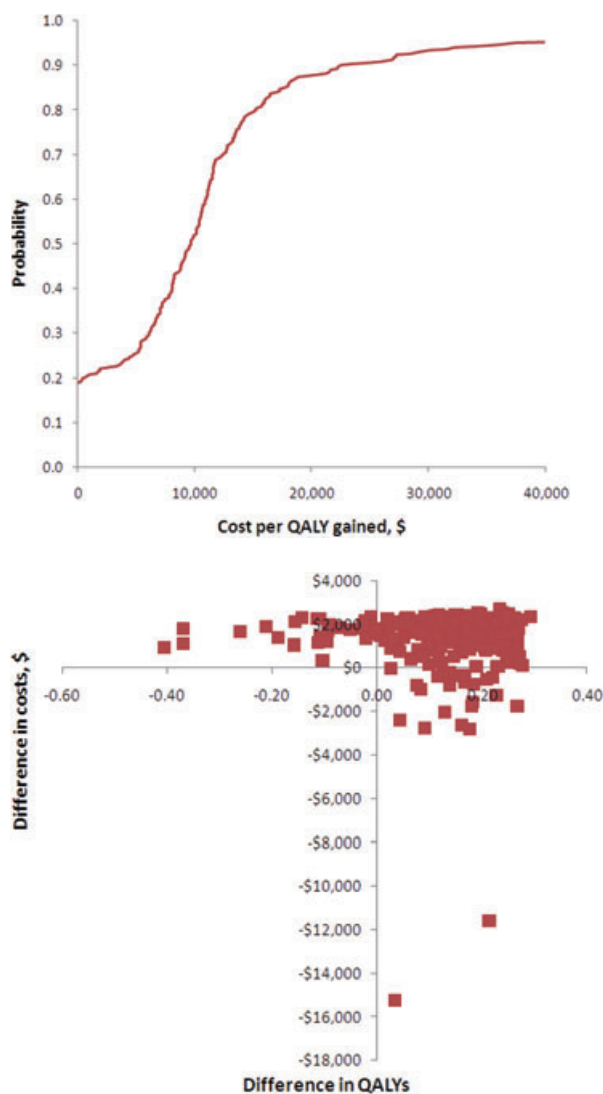

Figure 3 Acceptability curve and scatterplot. QALY, quality-adjusted life-years.

ment recommendation. Second, the utilities applied in the model were derived from the English-speaking literature and may not fully characterize the preferences of patients in Israel. Third, the validation of the assay was based on clinical trials conducted in the United States [7,8]. Studies are underway in other countries, such as Japan, to assess whether the findings of the pivotal trials are maintained in other settings [29]. Fourth, we omitted some potential long-term implications of breast cancer and its treatments, such as the risk of local recurrence and risk of second primary tumors associated with chemotherapy, as a result of limited data [15,16,30]. Fifth, we examined the effect of the test from the payer's perspective. As such, we have not included savings associated with lower indirect costs accruing to patients, such as reduced work absenteeism associated with the chemotherapy regimen and management of its adverse events.

Conclusions

The CHS found that testing 368 patients with ER+, LN-, ESBC with *Oncotype DX* increased their health-care costs by \$1,500,000. These higher overall costs associated with testing in Israel, relative to cost-savings that have been estimated for the United States, is likely consequence of the higher expenditures per patient in the Israel for adjuvant chemotherapy and its administration. The benefits realized by patients were associated with the avoidance of a loss in quality of life related to the lower incidence of early adverse events (e.g., nausea/vomiting, hair loss, and infections) from the reduced use of adjuvant chemotherapy. Patients at low risk of recurrence who decided to forego adjuvant chemotherapy can be reasonably expected to worry less about the risk of late adverse events, such as cognitive dysfunction, infertility, and second primary tumors. Among patients at high risk of recurrence who switched to receiving adjuvant chemotherapy, they were projected to benefit from a 25% to 30% lower risk of recurrence and associated mortality from breast cancer. Overall, *Oncotype DX* was projected to cost on average no more than \$11,000 per QALY gained, a value that is less than one-half of generally accepted cost-effectiveness thresholds in developed countries such as Israel [28].

Source of financial support: Teva Pharmaceutical Industries Ltd., Kiryat Nordau, Netanya, Israel.

References

- Freedman LS, Edwards BK, Ries LAG, Young JL (eds). Cancer Incidence in Four Member Countries (Cyprus, Egypt, Israel, and Jordan) of the Middle East Cancer Consortium (MECC) Compared with US SEER. National Cancer Institute, Bethesda, MD, 2006. NIH Pub. No. 06-5873.
- Mathers C, Boerna T, Ma Fat D, et al. The Global Burden of Disease: 2004 Update. Geneva, Switzerland: World Health Organization, 2008.
- Fisher B, Brown AM, Dimitrov NV, et al. Two months of doxorubicin-cyclophosphamide with and without interval reinduction therapy compared with 6 months of cyclophosphamide, methotrexate, and fluorouracil in positive-node breast cancer patients with tamoxifen-nonresponsive tumors: results from the National Surgical Adjuvant Breast and Bowel Project B-15. *J Clin Oncol* 1990;8:1483-96.
- National Comprehensive Cancer Network, Inc. Breast Cancer, V.1.2009. 2008. Available from: http://www.nccn.org/professionals/physician_gls/f_guidelines.asp [Accessed June 18, 2009].
- Vacek PM, Geller BM, Weaver DL, Foster RS, Jr. Increased mammography use and its impact on earlier breast cancer detection in Vermont, 1975-1999. *Cancer* 2002;94:2160-8.
- Fisher B, Dignam J, Wolmark N, et al. Tamoxifen and chemotherapy for lymph node-negative, estrogen receptor-positive breast cancer. *J Natl Cancer Inst* 1997;89:1673-82.
- Paik S, Shak S, Tang G, et al. A multigene assay to predict recurrence of tamoxifen-treated, node-negative breast cancer. *N Engl J Med* 2004;351:2817-26.
- Paik S, Tang G, Shak S, et al. Gene expression and benefit of chemotherapy in women with node-negative, estrogen receptor-positive breast cancer. *J Clin Oncol* 2006;24:3726-34.
- Asad J, Jacobson A, Estabrook A, et al. Does *Oncotype DX* Recurrence Score affect the management of patients with early stage breast cancer? *Am J Surg* 2008;196:527-9.
- Oratz R, Paul D, Cohn A, Sedlacek S. Impact of a commercial reference laboratory test recurrence score on decision making in early-stage breast cancer. *J Oncol Pract* 2007;3:182-6.
- Mumby P, Lo S, Norton J, et al. Prospective multi-center study of the impact of the 21-gene recurrence score assay on patient satisfaction, anxiety and decisional conflict for adjuvant breast cancer treatment selection. Abstract #1092. In: 30th Annual San Antonio Breast Cancer Symposium, December 13, 2007; San Antonio, TX.
- Thanasoulis T, Brown A, Frazier T. The role of *Oncotype DX* assay on appropriate treatment for estrogen positive, lymph node negative invasive breast cancer. American Society of Breast Surgeons Annual Meeting; 2008; New York, NY; 2008.
- Erb C, Fox K, Patel M, et al. Evaluation of practice patterns in the treatment of node-negative, hormone-receptor positive breast cancer patients with the use of the *Oncotype DX* assay at the University of Pennsylvania. Abstract #3082. In: 30th Annual San Antonio Breast Cancer Symposium, December 14, 2007; San Antonio, TX.
- Ben-Baruch N, Hammerman A, Klang S, Liebermann N. A prospective study of the impact of the 21-gene recurrence score assay on treatment decisions in N-, ER+ early stage breast cancer patients. Abstract #11008. In: ASCO Annual Meeting, June 20, 2007; Chicago, IL.
- Hornberger J, Cosler LE, Lyman GH. Economic analysis of targeting chemotherapy using a 21-gene RT-PCR assay in lymph-node-negative, estrogen-receptor-positive, early-stage breast cancer. *Am J Manag Care* 2005;11:313-24.
- Lyman G, Cosler LE, Kuderer NM, Hornberger J. Impact of a 21-gene RT-PCR assay on treatment decisions in early-stage breast cancer: an economic analysis based on prognostic and predictive validation studies. *Cancer* 2007;109:1011-18.
- Department of Health and Human Services, Centers for Disease Control and Prevention, and National Cancer institute. United States Cancer Statistics: 1999-2005 Incidence and Mortality Web-Based Report. Atlanta, GA: Department of Health and Human Services, Centers for Disease Control and Prevention, and National Cancer institute, 2009.
- Lipscomb J, Weinstein M, Torrance G. Cost-Effectiveness in Health and Medicine. New York: Oxford University Press, 1996.
- Brennan V, Wolowacz S. A systematic review of breast cancer utility weights. Abstract #PCN77. ISPOR 13th Annual International Meeting 2008, May 3-7, 2009, Toronto, Ontario, Canada.
- Simes R, Coates AS. Patient preferences for adjuvant chemotherapy of early breast cancer: how much benefit is needed? *J Natl Cancer Inst Monogr* 2001;30:146-52.
- Lindley C, Vasa S, Sawyer WT, et al. Quality of life and preferences for treatment following systemic adjuvant therapy for early-stage breast cancer. *J Clin Oncol* 1998;16:1380-7.
- Ravdin P, Siminoff IA, Harvey JA. Survey of breast cancer patients concerning their knowledge and expectations of adjuvant therapy. *J Clin Oncol* 1998;16:515-21.
- Zimmermann C, Baldo C, Molino A. Framing of outcome and probability of recurrence: Breast cancer patients' choice of adjuvant chemotherapy (ACT) in hypothetical patient scenarios. *Breast Cancer Res Treat* 2000;60:9-14.
- Braithwaite RS, Roberts MS, Justice AC. Incorporating quality of evidence into decision analytic modeling. *Ann Intern Med* 2007;146:133-41.

- 25 Atkins D, Best D, Briss PA, et al. Grading quality of evidence and strength of recommendations. *BMJ* 2004;328:1490.
- 26 American Joint. Committee on Cancer. *AJCC Cancer Staging Manual* (6th ed.). New York: Springer, 2002.
- 27 Harris L, Fritsche H, Mennel R, et al. American Society of Clinical Oncology 2007 update of recommendations for the use of tumor markers in breast cancer. *J Clin Oncol* 2007;25:5287–312.
- 28 Feachem RG. Commission on Macroeconomics and Health. *Bull World Health Organ* 2002;80:87.
- 29 Kondo M, Hoshi SL, Ishiguro H, et al. Economic evaluation of 21-gene reverse transcriptase-polymerase chain reaction assay in lymph-node-negative, estrogen-receptor-positive, early-stage breast cancer in Japan. *Breast Cancer Res Treat* 2008;112:175–87.
- 30 Marchionni L, Wilson R, Marinopoulos S, et al. Impact of Gene Expression Profiling Tests on Breast Cancer Outcomes. Evidence Report/Technology Assessment No. 160. (Prepared by The Johns Hopkins University Evidence-based Practice Center under contract No. 290-02-0018). AHRQ Publication No. 08-E002. Rockville, MD: Agency for Healthcare Research and Quality. January 2008.